

**ADVANCED 4-HEAD
PLAY-BACK AND RECORD AMPLIFIER FOR VCR**

PLAY-BACK MODE

- LOW NOISE AND WIDE BAND AMPLIFIERS FOR 4 HEADS
- AUTOMATIC OFFSET CANCELLATION BETWEEN THE 2 SELECTED HEADS
- ONE PLAY-BACK OUTPUT WITHOUT AGC
- ONE PLAY-BACK OUTPUT INCLUDING AGC
- RECORD AMPLIFIER INHIBITION AND RECORD OUTPUTS GROUNDED
- OUTPUT FOR TRACKING VIDEO INFORMATION (TRIV) WITH ADJUSTABLE GAIN
- SHORT PLAY/LONG PLAY ENVELOPE COMPARATOR WITH SCHMIDT TRIGGER OUTPUT

RECORD MODE

- TWO INTEGRATED I/I CONVERTERS WITH ACCURATE CONTROL OF TRANSCONDUCTANCE
- AUTOMATIC PLAY-BACK/RECORD SWITCHING BY SCANNING OF RECORD SUPPLY
- PLAY-BACK LOOP INHIBITION

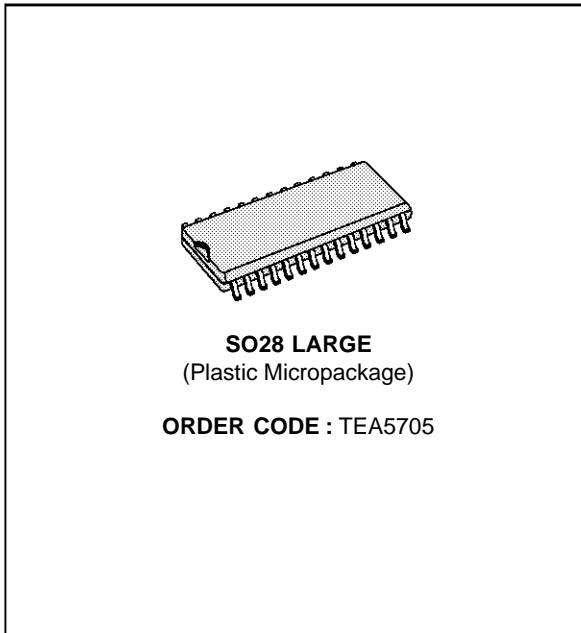

PIN DESCRIPTION

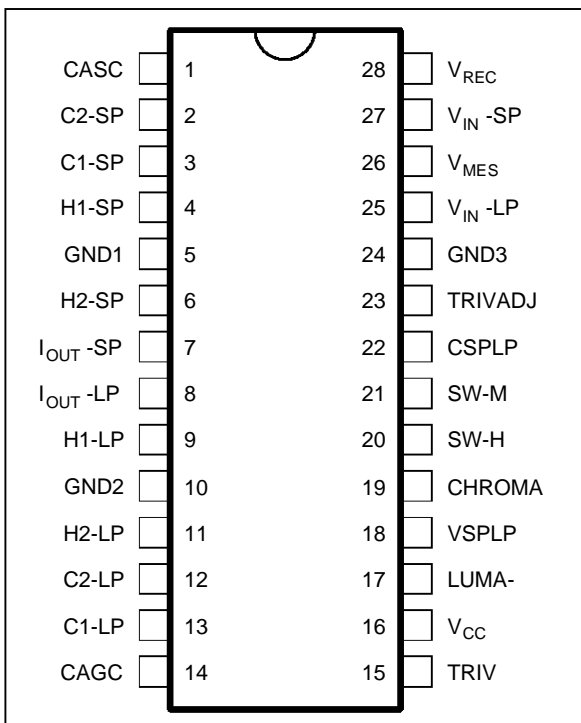

DESCRIPTION

The TEA5705 is an advanced four head record and play-back amplifier for VCR.

BLOCK DIAGRAM

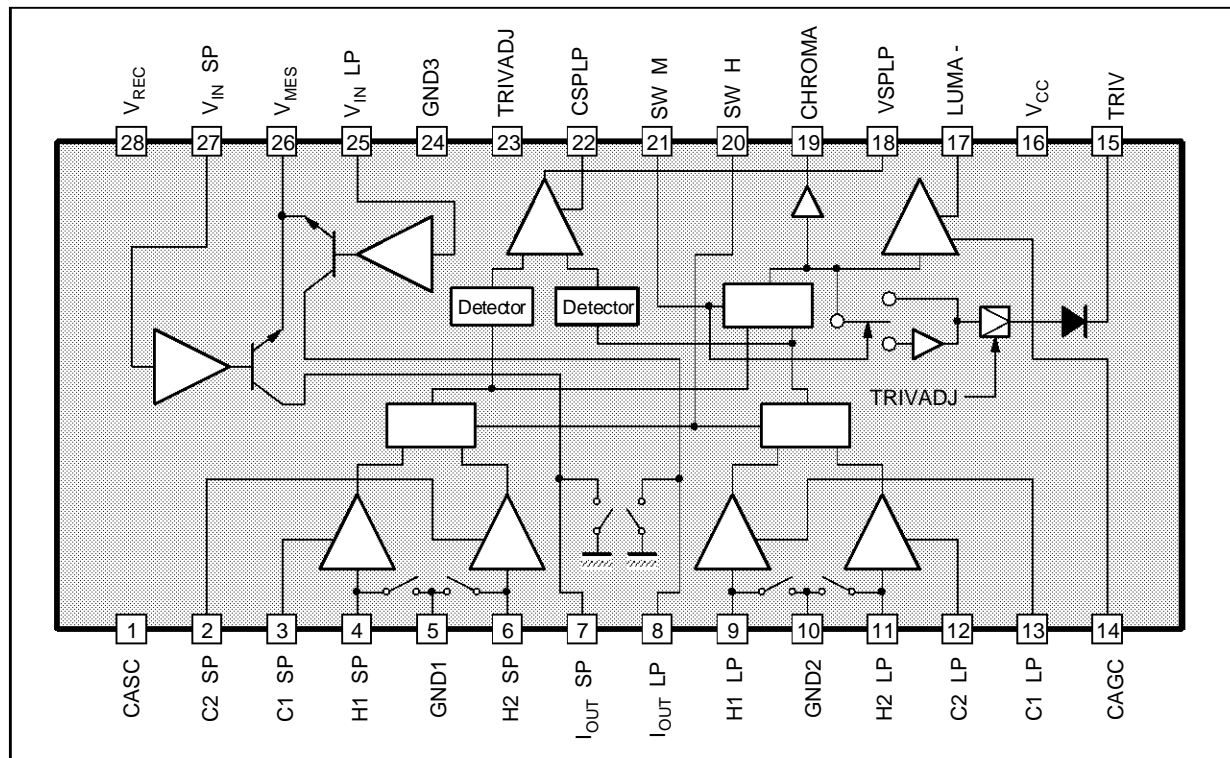

5705-02.EPS

FUNCTIONAL DESCRIPTION

TEA5705 is intended for 4 heads VCR applications. It includes all the electrical functions necessary to achieve play-back and record processing for VHS and S-VHS applications (10MHz bandwidth).

High performance technology allows very low noise levels (current and voltage), which are frequency independent in all the frequency range. In play-back mode a special feature suppresses the DC offset when switching two channels. Optimized play-back output stage gives to the TEA5705 large capability to drive directly a coaxial cable in order to reduce number of external components.

Two play-back outputs are available : one, dedicated to Chroma processing, is a 60dB voltage amplifier output, the other, dedicated to Luma processing, is phase opposite signal with a constant AC output level of 200mV_{PP} at 3.8MHz signal.

A tracking information for video signal (TRIV) is Luma amplitude proportional and allows automatic phase correction. The transfer function has a gain of 2.5dB higher when a LP channel is selected. Adding to this, a gain control bloc allows to modify the gain (± 6 dB) of the TRIV function for all the channels by applying a bias on pin TRIVADJ.

An automatic scanning of record supply voltage

permits TEA5705 automatically switching either in play-back or in record mode. The switching threshold voltage is fixed to a value which forbids high current peaking through the heads.

During play-back mode, record output is grounded via an internal transistor and during record mode preamplifiers are turned off.

There is one output current for two recording heads, the DC current and the AC characteristics can be very precisely controlled with accurate external resistors. If recommended resistances are used, a $\pm 3\%$ transconductance accuracy is guaranteed. Feedback loop gains of SP channel and LP channel can be different.

A particular feature is the SP/LP envelope comparator and detector. This system can be used in search mode, still mode, slow mode... The output signal is an output current feeding a capacitor (CSPLP) which is buffered through a schmidt trigger circuit to VSPLP. This output is high in record mode. By varying the capacitance on CSPLP a good compromise can be found between short delay time and spike free signal.

TEA5705 is fully protected against ESD.

ABSOLUTE MAXIMUM RATINGS

Symbol	Parameter	Value	Unit
V _{CC}	Power Supply Voltage	6	V
V _{REC}	Power Supply Voltage Record	15	V
T _J	Junction Temperature	+150	°C
T _{oper}	Operating Temperature	0, +70	°C

5705-01.TBL

THERMAL DATA

Symbol	Parameter	Value	Unit
R _{th(j-a)}	Junction-ambient Thermal Resistance	Typ. 70	°C/W

5705-02.TBL

RECOMMENDED OPERATING CONDITIONS (T_{amb} = 25°C)

Symbol	Parameter	Min.	Typ.	Max.	Unit
V _{CC}	Power Supply Voltage	4.5	5	5.5	V
V _{REC}	Power Supply Voltage Record	4.75	11.3	12.6	V
CAGC	Capacitance at Pin CAGC	4.7			nF
CSPLP	Capacitance at Pin CSPLP		4.7		nF

5705-03.TBL

ELECTRICAL OPERATING CHARACTERISTICS (T_{amb} = 25°C unless otherwise specified)**Power Consumption**

Parameter	Play-Back		Record (1)	
	Typ.	Max.	Typ.	Max.
V _{CC}	55mA	70mA	40mA	50mA
V _{REC}	0mA	0mA	27mA	33mA
Total Consumption (2)	V _{CC} = 5V, V _{REC} = 9V		478mW	
	V _{CC} = 5.5V, V _{REC} = 9.45V		630mW	

5705-04.TBL

- Notes :** 1. R1 = 18Ω
2. Taking in account only the consumption through the IC.

A great care should be taken to the maximum power consumption : V_{REC} can be increased to 12.6V if the DC current flowing through the head is reduced. This can be done by increasing R1 value. V_{REC} can be reduced as long as voltage on Pins I_{OUT-SP}, I_{OUT-LP} is not going under 1V (to forbid output stage saturation).

Play-back ModeV_{CC} = 5V, no load on Pins CHROMA, LUMA-

Symbol	Parameter	Test Conditions	Min.	Typ.	Max.	Unit
I _{CC1}	Supply Current		45	55	70	mA

CHROMA OUTPUT (no AGC)

G _{PB}	Pre-amplification Gain	Sinewave 600 kHz 400mV _{PP} on output Input on Pin H1-SP or H2-SP, H1-LP or H2-LP	57	60	63	dB
ΔG _{PB1}	Difference of Output Signal on Pin CHROMA between Channel 1 and Channel 2 in SP Mode	Sinewave 600kHz 0.4mV _{PP} on inputs H1-SP and H2-SP	-1.2	0	1.2	dB
ΔG _{PB2}	Difference of Output Signal on Pin CHROMA between Channel 1 and Channel 2 in LP Mode	Sinewave 600kHz 0.4mV _{PP} on inputs H1-LP and H2-LP	-1.2	0	1.2	dB
e _N	Equivalent Input Voltage Noise Level	Input grounded via switching transistor on Pins H1-SP, H2-SP, H1-LP, H2-LP, F = 600kHz		0.6		nV/√Hz
i _N	Equivalent Input Current Noise	Pins H1-SP, H2-SP, H1-LP, H2-LP		1.7		pA/√Hz

5705-05.TBL

ELECTRICAL OPERATING CHARACTERISTICS ($T_{amb} = 25^{\circ}\text{C}$ unless otherwise specified) (continued)**Play-back Mode** $V_{CC} = 5\text{V}$, no load on Pins CHROMA, LUMA-

Symbol	Parameter	Test Conditions	Min.	Typ.	Max.	Unit
CHROMA OUTPUT (no AGC) (continued)						
CRT	Crosstalk	Sine wave 3.8MHz 400 μV_{PP} on input, All the other inputs loaded with $R_g = 15\Omega$		-45	-40	dB
R_{PB}	Playback Switch-on Resistance	$\Delta I = 10\text{mA}$		2.0	5.0	Ω
F_{LCPB1} F_{HCPB1}	Bandwidth Cut-off Frequency	-3dB attenuation 50 Ω in parallel on the input, 0dB at 600kHz Low High	8	13.5	0.1	MHz MHz
C_{IN}	Input Capacitance Pins H1-SP, H2-SP, H1-LP, H2-LP	At 5MHz		30	40	pF
R_{IN}	Pre-amplifier Input Resistance Pins H1-SP, H2-SP, H1-LP, H2-LP	At 3.8MHz	400	600	900	Ω
Z_{CPB}	Output Impedance Pin CHROMA	DC		24	50	Ω
V_{DCPB1}	DC Level at Play-back Output on Pin CHROMA		1.5	1.9	2.3	V
ΔV_{DCSP} ΔV_{DCLP}	Head Switch Offset Pin CHROMA		-100 -100	0 0	100 100	mV mV
SH_{PB1}	Second Harmonic Play-back Output Pin CHROMA	Sinus wave 3.8MHz 400 μV_{PP} on input		-45	-40	dB

LUMA- OUTPUT (with AGC)

Z_{LPB}	Output Impedance	DC		30	50	Ω
V_{DCPB2}	DC Level		1.1	1.5	2.1	V
F_{LCPB2} F_{HCPB2}	Bandwidth Cut-off Frequency	-3dB attenuation 50 Ω in parallel on the input, AGC locked, 0dB at 3.8MHz Low High	10	12.5	0.1	MHz MHz
V_{LPB}	Output Amplitude	Input signal 200 μV_{PP} at 3.8MHz on Pins H1-SP, H2-SP, H1-LP, H2-LP	140	200	270	mV $_{PP}$
ΔV_{LPB}	AGC Control Sensitivity	Input signal 200 μV_{PP} at +6dB or -5dB on Pins H1-SP, H2-SP, H1-LP, H2-LP	-2		+1	dB
SH_{PB2}	Second Harmonic Play-back Output	Input Signal 3.8MHz 400 μV_{PP} on Pins H1-SP, H2-SP, H1-LP, H2-LP		-44	-40	dB

CAGC

I+	Positive Output Current	Input Signal 3.8MHz 200 μV_{PP} on H1-SP	15	30	50	μA
I-	Negative Output Current	Input Signal 3.8MHz 200 μV_{PP} on H1-SP	-50	-30	-15	μA

TRIV

I_{TRIV}	Downloading Current		200	300	400	μA
V_{TRIV1}	Output Level (1)	With no signal, $V_{TRIVADJ} = 2.5\text{V}$ Mode LP (SW-M = high)	0.3	0.6	1	V
V_{TRIV2}	Output Level (2)	$V_{CHROMA} = 100\text{mV}_{PP}$ at 4MHz $V_{TRIVADJ} = 2.5\text{V}$, Mode LP (SW-M = high)	1.91	2.31	2.71	V
V_{TRIV3}	Output Level (3)	$V_{CHROMA} = 400\text{mV}_{PP}$ at 4MHz $V_{TRIVADJ} = 2.5\text{V}$, Mode LP (SW-M = high)	3.525	3.725	3.925	V
V_{TRIV4}	Output Level (4)	$V_{CHROMA} = 100\text{mV}_{PP}$ at 4MHz $V_{TRIVADJ} = 1\text{V}$, Mode LP (SW-M = high)	1.11	1.61	2.11	V
V_{TRIV5}	Output Level (5)	$V_{CHROMA} = 100\text{mV}_{PP}$ at 4MHz $V_{TRIVADJ} = 4\text{V}$, Mode LP (SW-M = high)	2.875	3.075	3.275	V
V_{TRIV6}	Output Level (6)	$V_{CHROMA} = 400\text{mV}_{PP}$ at 4MHz $V_{TRIVADJ} = 2.5\text{V}$, Mode SP (SW-M = low)	3.215	3.415	3.615	V

5705-06.TBL

ELECTRICAL OPERATING CHARACTERISTICS ($T_{amb} = 25^{\circ}\text{C}$ unless otherwise specified) (continued)**Play-back Mode** $V_{CC} = 5\text{V}$, no load on Pins CHROMA, LUMA-

Symbol	Parameter	Test Conditions	Min.	Typ.	Max.	Unit
TRIV (continued)						
V_{TRIV7}	Output Level (7)	$V_{CHROMA} = 100\text{mV}_{PP}$ at 4MHz $V_{TRIVADJ} = 2.5\text{V}$, Mode SP (SW-M = low)	1.65	2.05	2.45	V
f_{TRIV1}	Response Lower Frequency	$V_{CHROMA} = 360\text{mV}_{PP}$ at 4MHz and 1MHz $V_{TRIVADJ} = 2.5\text{V}$, Mode LP (SW-M = high)	-10	-6	-3	dB
f_{TRIV2}	Response Higher Frequency	$V_{CHROMA} = 360\text{mV}_{PP}$ at 8MHz and 4MHz $V_{TRIVADJ} = 2.5\text{V}$, Mode LP (SW-M = high)	-2.5	-1	-0	dB
G_{TRIV}	High Level Input	LP : $V_{CHROMA} = 100\text{mV}_{PP}$, 300mV_{PP} at 4MHz, $V_{TRIVADJ} = 2.5\text{V}$	4	5.5	7	V/V

SP/LP ENVELOPE DETECTOR

I_{DET+}	Current Output on Pin CSPLP	$200\mu\text{V}_{PP}$ on Pins H1-SP or H2-SP	25	55	85	μA
I_{DET-}	Current Output on Pin CSPLP	$200\mu\text{V}_{PP}$ on Pins H1-LP or H2-LP	-85	-55	-25	μA
V_{DETH}	Sensitivity 1 on Pin CSPLP	$50\mu\text{V}_{PP}$ to $600\mu\text{V}_{PP}$ on SP, LP short circuited	4	4.5	5	V
V_{DETL}	Sensitivity 2 on Pin CSPLP	$50\mu\text{V}_{PP}$ to $600\mu\text{V}_{PP}$ on LP, SP short circuited	0	0.5	1	V
V_{TH}	Upper Threshold on Pin VSPLP	Scanning through Pin CSPLP		3.33		V
V_{TL}	Lower Threshold on Pin VSPLP	Scanning through Pin CSPLP		1.66		V
R_{OH} R_{OL}	Output Resistance on Pin VSPLP	Output high Output low	7.5 1.5	12.5 2.5	17.5 3.5	$\text{k}\Omega$ $\text{k}\Omega$

Record Mode $V_{REC} = 11.3\text{V}$, $V_{CC} = 5\text{V}$, Load resistor 50Ω on Pin I_{OUT-SP} , I_{OUT-LP}

Transconductance network defined by :

- $R_1 = 18\Omega$, 1% Pins GND/ V_{MES}
- $R_2\text{-SP} = 2\text{k}\Omega$, 1% Pins V_{MES}/V_{IN-SP}
- $R_2\text{-LP} = 1.5\text{k}\Omega$, 1% Pins V_{MES}/V_{IN-SP}
- $R_3\text{-SP} = 1.5\text{k}\Omega$, 1% Pin V_{IN-SP}
- $R_3\text{-LP} = 1.5\text{k}\Omega$, 1% Pin V_{IN-LP}

Symbol	Parameter	Test Conditions	Min.	Typ.	Max.	Unit
I_{REC} I_{CC2}	Current Supply	$V_{REC} = 11.3\text{V}$ $V_{CC} = 5\text{V}$	17 30	25 43	33 56	mA mA
I_{max}	Max. Record Current on SP or LP Current Amplifier	3.8MHz	35			mA_{PP}
TR	Transconductance	$V_{IN-SP} = 300\text{mV}_{PP}$ $V_{IN-LP} = 300\text{mV}_{PP}$	55 45	74 55	85 65	mA/V mA/V
SH_{REC}	Second Harmonic	Output Current, 30mA_{PP} at 3.8MHz at Pin I_{OUT-SP} at Pin I_{OUT-LP}		-54 -54	-38 -38	dB dB
F_{LCRSP} F_{HCRSP}	Bandwidth Cut-off Frequency Pin I_{OUT-SP}	-3dB attenuation, 0dB at 3.8MHz Output current 30mA_{PP} Low High	10		0.1	MHz MHz
V_{SPLPV}	DC Level at Pin VSPLP		4			V
F_{LCRLP} F_{HCRLP}	Bandwidth Cut-off Frequency Pin I_{OUT-LP}	-3dB attenuation, 0dB at 3.8MHz Output current 30mA_{PP} Low High	10		0.1	MHz MHz
R_{VIN-SP} R_{VIN-LP}	Input Resistance on Pins V_{IN-LP} , V_{IN-SP}	Equivalent value of R3 resistor	500	700	900	Ω

5705-07.TBL

ELECTRICAL OPERATING CHARACTERISTICS ($T_{amb} = 25^{\circ}C$ unless otherwise specified) (continued)

Switching Levels

Symbol	Parameter	Test Conditions	Min.	Typ.	Max.	Unit
V_{SWHH}	Head Selection Pin SW-H	Head number 1 in SP mode, 2 in LP mode	2.4		V_{CC}	V
V_{SWHL}		Head number 2 in SP mode, 1 in LP mode	0		1.5	V
I_{SWHH}		Input current (5V)	5	15	50	μA
I_{SWHL}		Output current (0V)	-50	-20	0	μA
V_{SWMH}	Mode Selection Pin SW-M (Record mode and play-back mode)	LP Mode	2.4		5	V
V_{SWML}		SP mode	0		1.5	V
I_{SWMH}		Input current (5V)	5	15	50	μA
I_{SWML}		Output current (0V)	-50	-20	0	μA
t_{ON} t_{OFF}	Selection Pin SW-H or SW-M Transient Response	Output signal appears on Pin CHROMA Delay time selection ON Delay time selection OFF		100 100	500 500	ns
V_{TH1}	Inhibition Threshold Hysteresis for Switching from Play-back to record on Pin V_{REC}	$V_{CC} = 5V$	0.15	0.3	0.5	V
V_{TH2}	Inhibition Threshold Hysteresis for Switching from Record to Play-back on Pin V_{REC}	$V_{CC} = 5V$		80		mV
t_1	Transient Response of Record Scanning on Pin V_{REC}	Delay from play-back to record (signal disappears on Pin CHROMA)		10		μs
t_2		Delay from record to play-back (signal appears on Pin CHROMA)		32*		ms
t_3		Delay from play-back to record (signal appears on Pin I_{OUT-SP} , I_{OUT-LP})		0.2		ms
t_4		Delay from record to play-back (signal disappears on Pin I_{OUT-SP} , I_{OUT-LP})		11*		ms

5705-08.TBL

* Depending on capacitance on Pin V_{REC} ; above values are according to the application diagram at page 9.

INPUT/OUTPUTS EQUIVALENT INTERNAL DIAGRAM

Pins : C1-SP, C2-SP, C1-LP, C2-LP

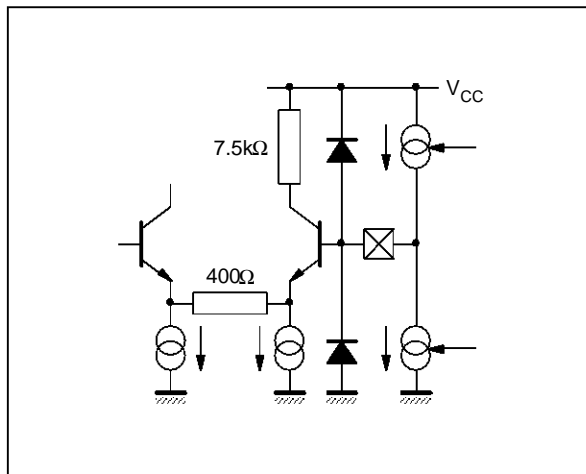

5705-03.EPS

Pins : SW-H, SW-M

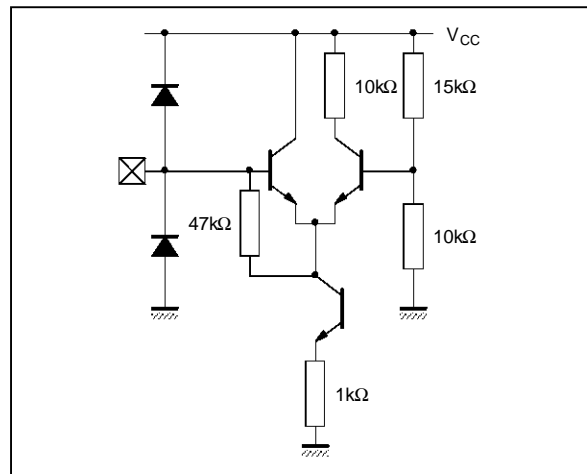

5705-04.EPS

INPUT/OUTPUTS EQUIVALENT INTERNAL DIAGRAM (continued)

Pins : Chroma, Luma-

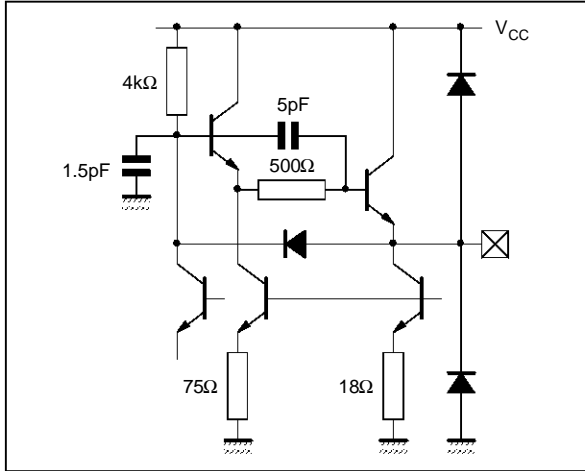

5705-05.EPS

Pin : VMES

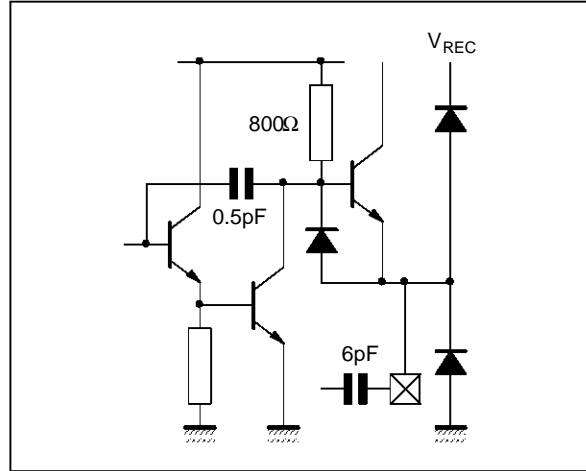

5705-06.EPS

Pin : VIN-SP, VIN-LP

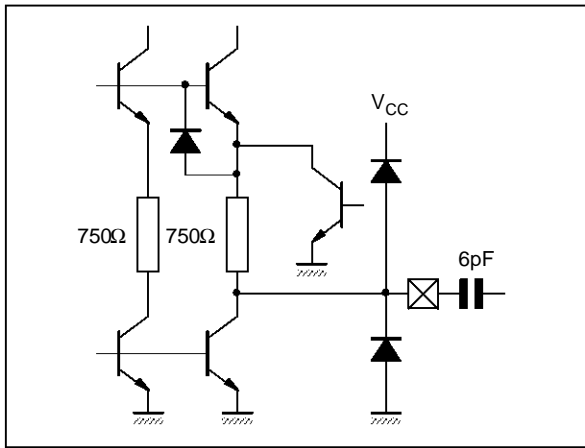

5705-07.EPS

Pin : CAGC

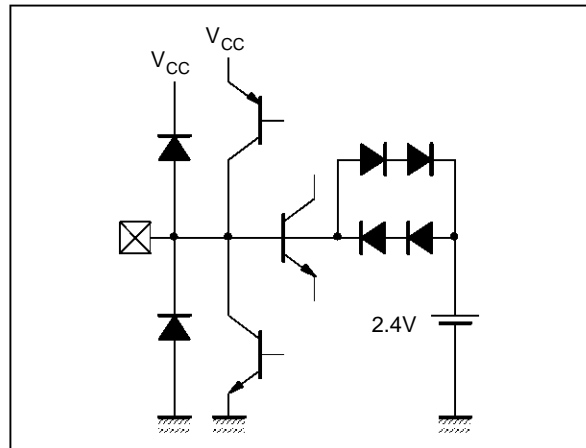

5705-08.EPS

Pin : TRIV

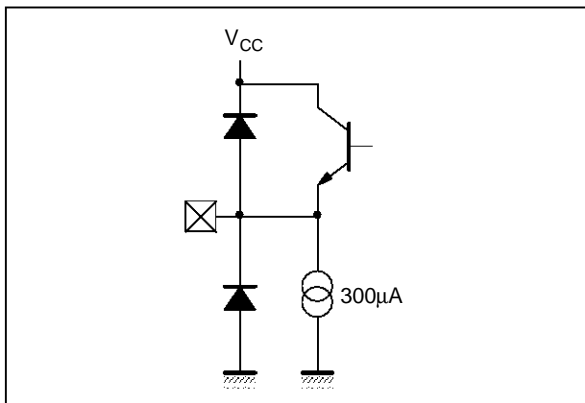

5705-09.EPS

Pin : TRIVADJ

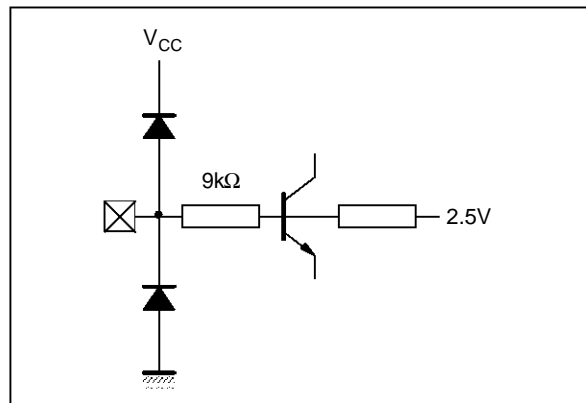

5705-10.EPS

INPUT/OUTPUTS EQUIVALENT INTERNAL DIAGRAM (continued)

Pin : Vcc

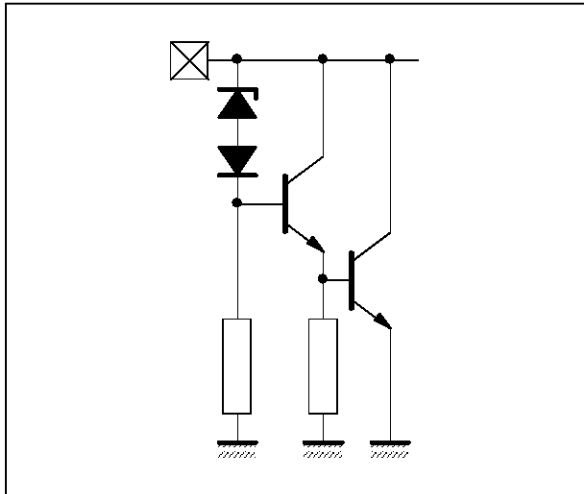

5705-11.EPS

Pin : VREC

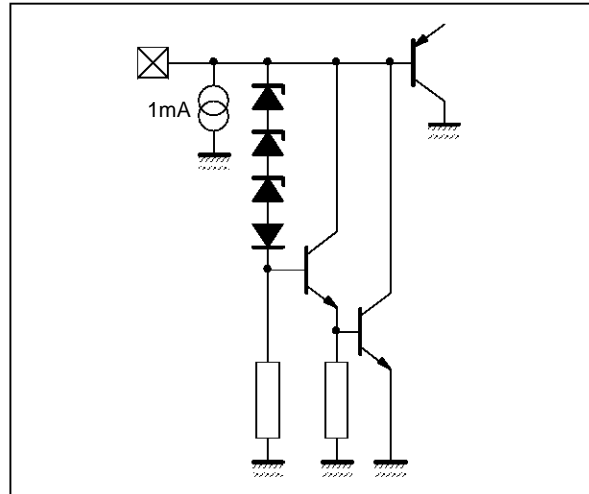

5705-12.EPS

Pin : IOUT-SP, IOUT-LP

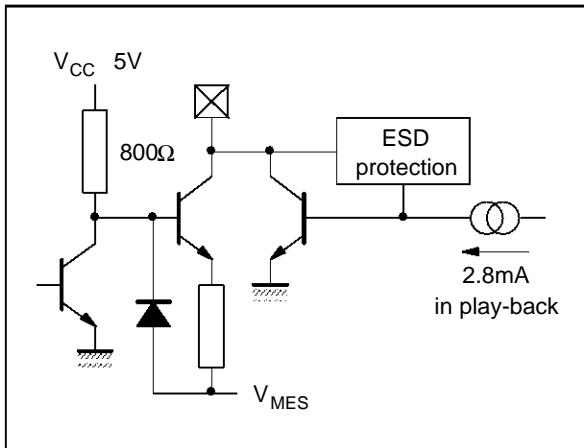

5705-13.EPS

Pins : CCAS, H1-SP, H2-SP, H1-LP, H2-LP

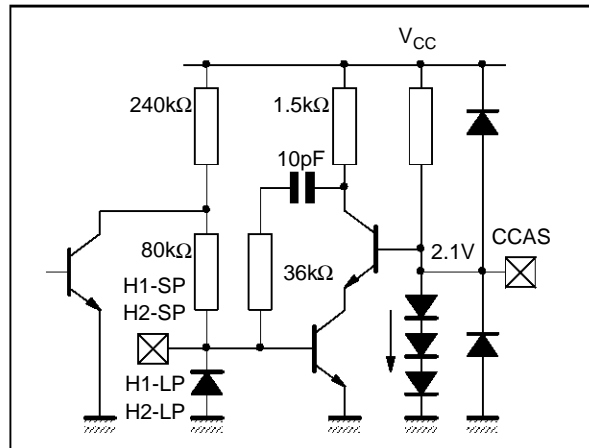

5705-14.EPS

Pin : CSPLP

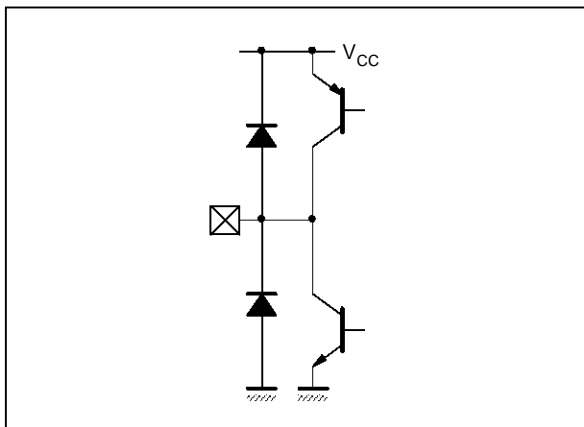

5705-15.EPS

Pin : VSPLP

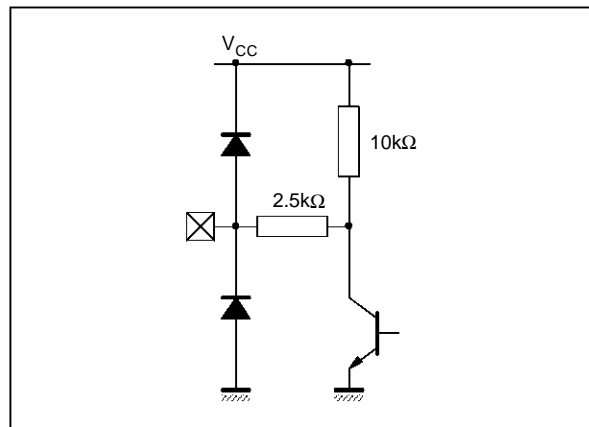

5705-16.EPS

APPLICATION DIAGRAM

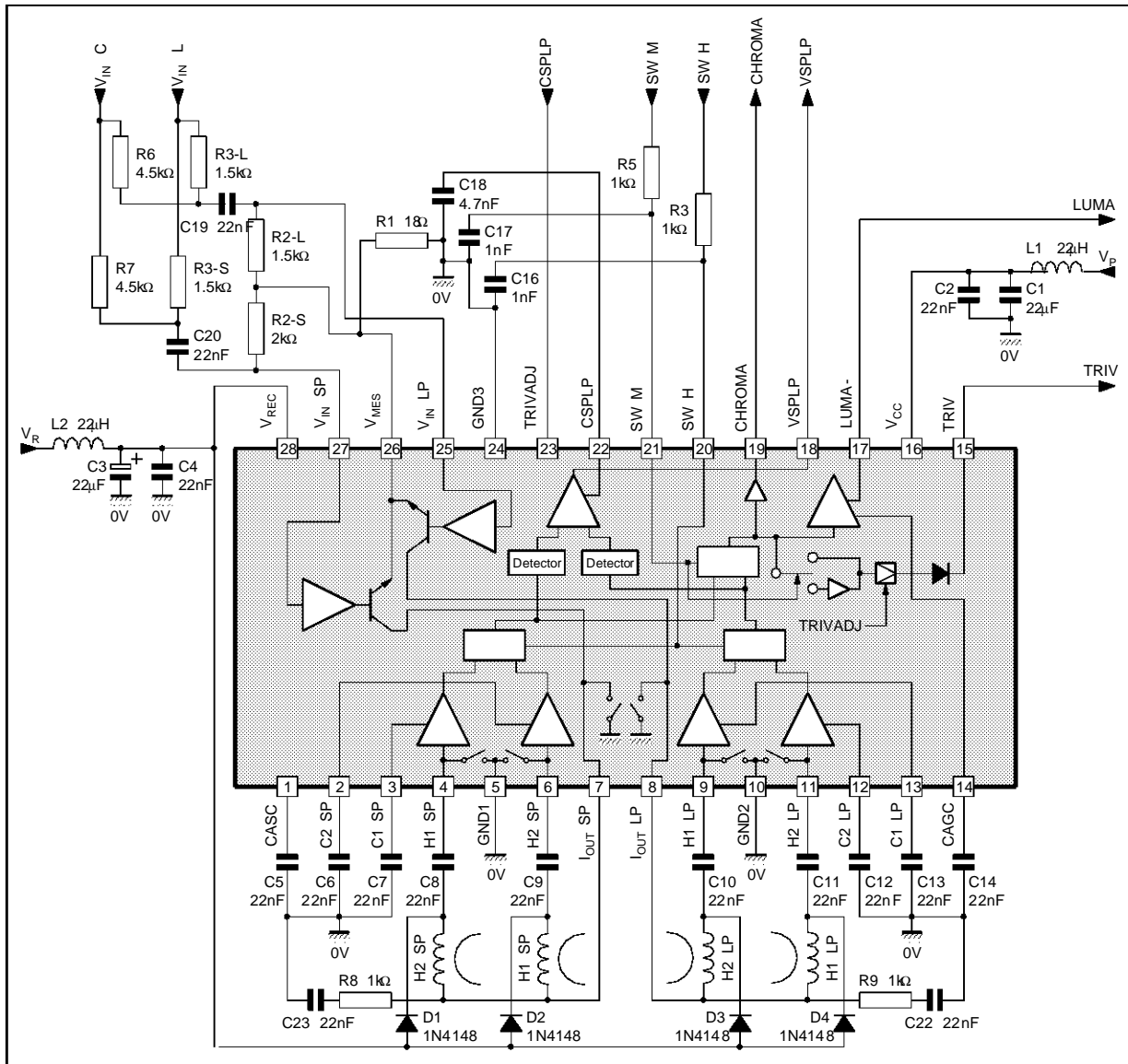

5705-17.EPS

PACKAGE MECHANICAL DATA
28 PINS - PLASTIC MICROPACKAGE

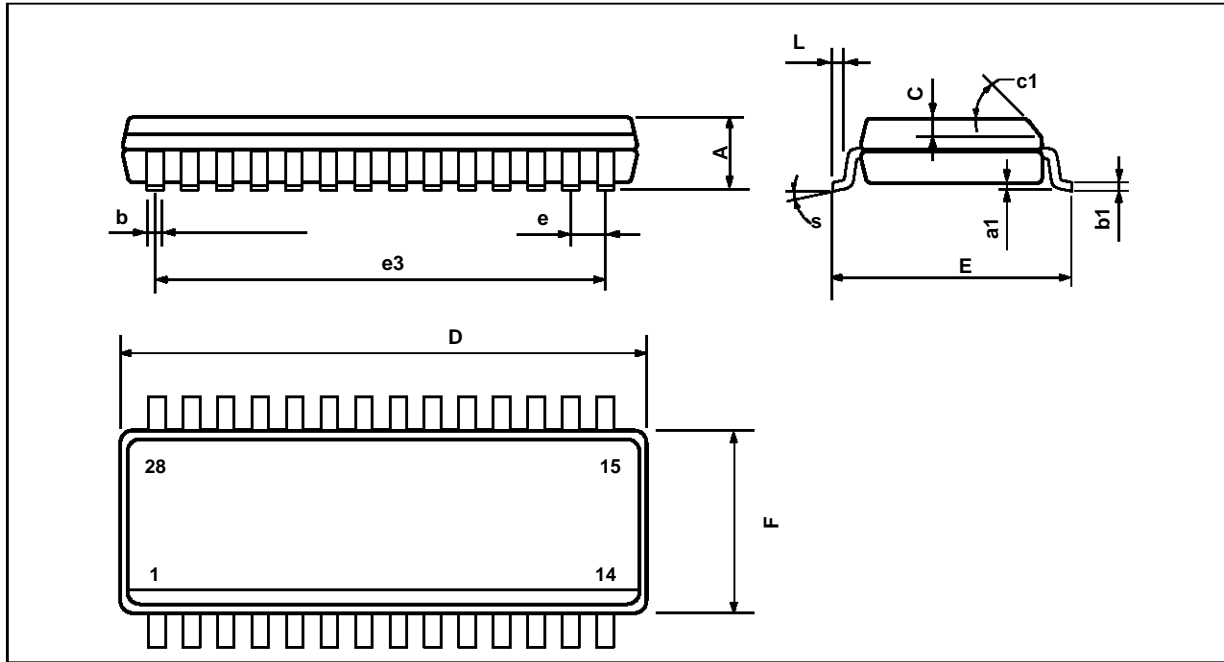

PM-S08.EPS

Dimensions	Millimeters			Inches		
	Min.	Typ.	Max.	Min.	Typ.	Max.
A			2.59			0.102
a1	0.05		0.20	0.002		0.008
b	0.31	0.41	0.51	0.012	0.016	0.020
b1	0.15		0.25	0.006		0.010
C		0.33			0.013	
D			18.13			0.714
E	10.11	10.31	10.51	0.399	0.406	0.414
e		1.27			0.050	
e3		16.51			0.65	
F	7.42	7.52	7.62	0.292	0.296	0.300
L	0.48	0.58	0.68	0.019	0.023	0.027
S	8° (max.)					

SC28B.TBL

Information furnished is believed to be accurate and reliable. However, SGS-THOMSON Microelectronics assumes no responsibility for the consequences of use of such information nor for any infringement of patents or other rights of third parties which may result from its use. No licence is granted by implication or otherwise under any patent or patent rights of SGS-THOMSON Microelectronics. Specifications mentioned in this publication are subject to change without notice. This publication supersedes and replaces all information previously supplied. SGS-THOMSON Microelectronics products are not authorized for use as critical components in life support devices or systems without express written approval of SGS-THOMSON Microelectronics.

© 1994 SGS-THOMSON Microelectronics - All Rights Reserved

Purchase of I²C Components of SGS-THOMSON Microelectronics, conveys a license under the Philips I²C Patent. Rights to use these components in a I²C system, is granted provided that the system conforms to the I²C Standard Specifications as defined by Philips.

SGS-THOMSON Microelectronics GROUP OF COMPANIES

Australia - Brazil - China - France - Germany - Hong Kong - Italy - Japan - Korea - Malaysia - Malta - Morocco
The Netherlands - Singapore - Spain - Sweden - Switzerland - Taiwan - Thailand - United Kingdom - U.S.A.